



APEX SINCE 1978



立式加工中心機

Model **PVM-500** 

VERTICAL MACHINING CENTER

Applicable Industries : Parts machining / Molds / Automotive and motorcycle parts / 3C industries / Clocks and watches industry 適用行業：機械加工 / 模具 / 模型 / 汽機車零件 / 3C產業 / 鐘錶業

機器特性

- 立柱加高設計，適合加裝第四軸旋轉工作台。
- X / Y / Z 軸全配置線性滑軌。
- X / Y / Z 軸快速位移 36米/分，可節省非切削時間 50%。
- BT-30，12,000 rpm 直結式主軸。
- 可選擇新代、寶元、三菱、發那科控制器。
- 前置式刀庫 16 刀。

Machine Features

- Increased height of column allows for installing additional 4th axis rotary table.
- Linear motion guides on X, Y, Z-axis.
- X, Y Z-axis rapid traverse rates reach 36 m/min, leading to 50% reduction of non-cutting time.
- BT-30, 12,000 rpm direct-drive spindle.
- SYNTEC, LNC, MITSUBISHI, FANUC Control.
- 16 tool prepositive type magazine.



X / Y / Z-axis are mounted with Linear motion guides
X / Y / Z 軸配置線性滑軌

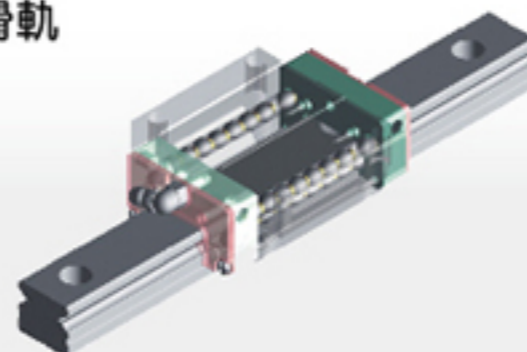

APEX CONNECTOR

Manufacturer

錫鋼精密科技股份有限公司
APEX PRECISION TECHNOLOGY CORP.

總公司 / 總廠：新北市新莊區民安西路405號 · Tel+886-2-2206-8899 · Fax+886-2-2208-0559
Add No. 405, Min-an W. Rd., Sinhuang District, New Taipei City 24264, Taiwan

台中 / 大雅廠：台中市大雅區民生路3段191巷4號、6號、8號 · Tel+886-4-2560-7272 · Fax+886-4-2565-2228
Add No.8, Ln. 191, Sec. 3, Minsheng Rd., Daya Dist, Taichung City 42844, Taiwan

www.plt.com.tw • apexmail@plt.com.tw • 認明商標 • 誠信責任

OEM / ODM

JAPAN BRANCH OFFICE / TECHNOLOGY R&D / IMPORT & EXPORT
株式会社 PLT JAPAN

28-1, Yoyogi 3-Chome, Shibuya-ku, Tokyo, Japan
TEL : +81-3-6276-8845 FAX : +81-3-6276-6645

AS9100D 航太國防工業品質管理系統認證通過
IATF 16949 全球汽車產業品質管理系統認證通過
ISO 14001 國際環境管理系統認證通過
ISO 9001 國際品質管理系統認證通過

S-187EO-849-2CH • Printed 2019/07



規格 / SPECIFICATION

機型	MODEL	PVM-500
工作台	TABLE	
工作台尺寸	Table Surface Size	550 x 400 mm
工作檯負重能力	Table Loading	250 kg
行程	TRAVEL AXIS	
X / Y / Z 軸行程	X / Y / Z axis Travel	500 x 430 x 330 mm
主軸鼻端至工作台	Spindle Nose to Table	200 ~ 580 mm
主軸	SPINDLE	
主軸馬達	Spindle Motor	3.7 / 5.5 kw
主軸最大轉速	Spindle Speed	12,000 rpm
主軸錐度	Spindle Taper	BT-30 (Direct Drive / 直結式)
進給馬達	AXIS MOTORS	
X / Y / Z 軸	X / Y / Z Axis	1.5 / 1.5 / 2.0 kw
X / Y / Z 軸快速位移	X / Y / Z Rapid Traverse	36 / 36 / 36 m/min
其它	OTHERS	
機器淨重	Machine Weight (N.W)	2,850 kg
機器尺寸	Machine Dimensions (W x D x H)	2,370 x 1,650 x 2,600 mm
所需氣壓	Air Pressure Required	6 ~ 8 kg/cm
電源容量	Power Consumption	15 KVA
T 型槽(寬 x 槽數 x 間距)	T - Slot (Width x No. x Dist.)	14 x 3 x 125 mm

• 由於不斷的持續研究與開發，本公司保有修改規格及不另行通知的權力。 • Due to continuous improvement and development, specifications are subject to change without prior notice.

PVM-500 標準配備

- 自動潤滑系統
- 切削冷卻裝置
- 外罩式鈹金
- 操作及程式手冊
- 工具箱
- 前置式16把刀 (BT-30)
- 熱交換器
- 水平調整螺栓及墊塊
- 工作燈及三層警示燈
- 剛性攻牙
- 油冷機

PVM-500 選購配備

- 電子探測器(自動刀具長度量測)
- 直結式主軸15,000 / 24,000 rpm
- 穩壓變壓器
- 油水分離機
- 第四軸旋轉工作台
- 油霧回收機
- 鐵屑輸送機

PVM-500 Standard Accessories

- Auto lubrication system
- Coolant system
- Full enclosure
- Operation and programming manual
- Tool box
- 16 tool prepositive type magazine (BT-30)
- Heat exchanger
- Leveling bolts and pads
- Working light and 3 color alarm indicator
- Rigid tapping
- Spindle cooler

PVM-500 Optional Accessories

- Electronic touch probe (A.T.L.M)
- 15,000 / 24,000 rpm direct drive spindle
- Automatic voltage regulator (A.V.R)
- Oil skimmer
- 4th axis rotary table
- Oil mist collector
- Chip conveyor



物美價廉 • 物超所值 **Excellent quality and competitive price !**

MEMO